



Invitation to Bid No. 2022-02-CHCH-01

Del Sol Clubhouse

3355 S Camino Del Sol, Green Valley, Arizona 85614

Pages C1.0 – C6.0:

Please ensure that the work shown on these pages are being included in the bid. The sitework set of drawings are being finalized and will be sent out ASAP. Please do not delay the pricing of these as there are only minor changes that should be made to the ones included in the architectural set.

Page C3.0:

Keynote 16: Details are provided as part of the architectural set, and are included at the end of this document.

Page C3.0:

Please provide an add alt to apply keynote 33 to the highlighted section below.

33 NEW PAVEMENT RESURFACING AND RESTRIPING TO BE COMPLETED DURING CONSTRUCTION. OWNER/ ARCHITECT TO PROVIDE DETAILS AND SPECIFICATIONS.

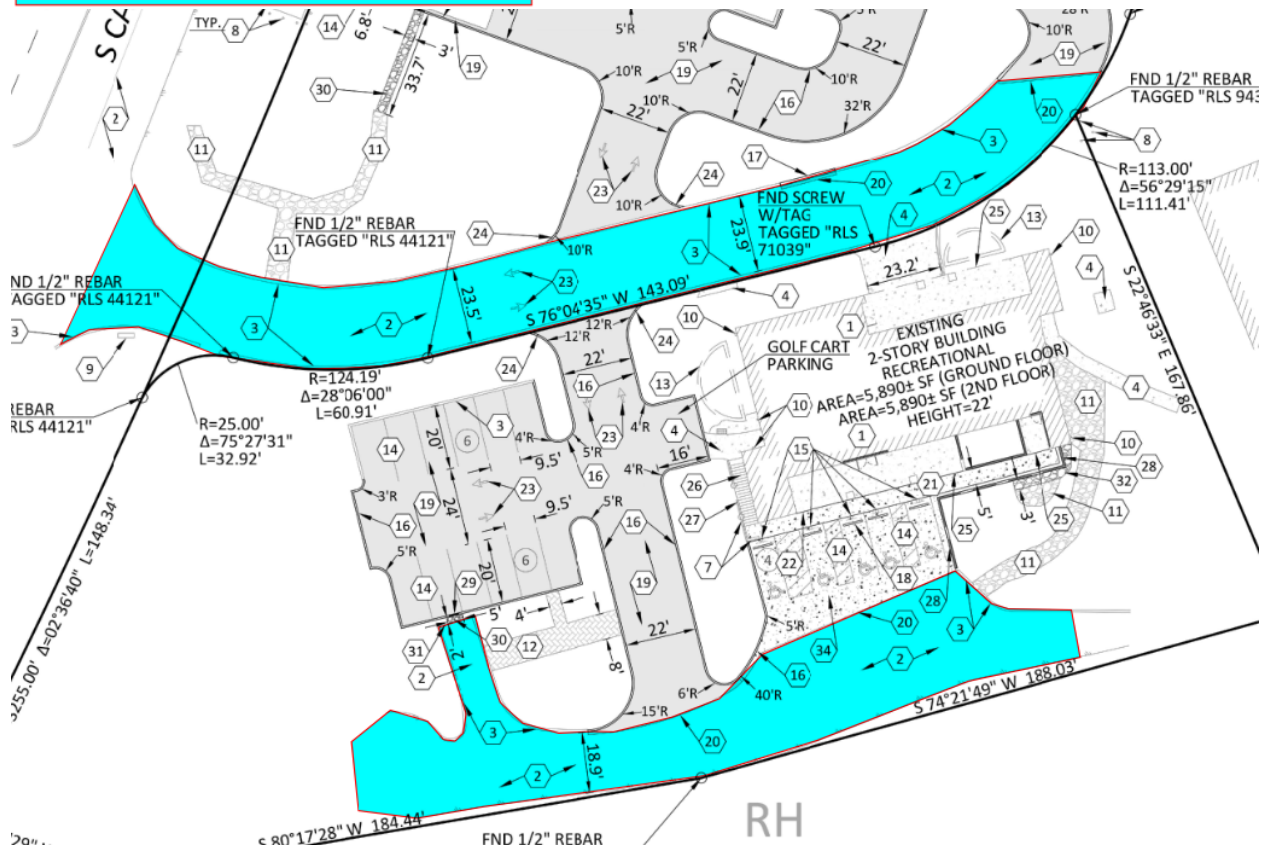

**Page A2.1 / S2.0: Wall infill**

A2.1 calls for CMU wall infill to be wall type A.

S2.0 calls for CMU wall infill to be CMU infill.

S22.0 is correct, we are infilling wall with CMU.

**Page A7.0: Finish Schedule**

F2:	Luxury Vinyl Tile: Series: Color:	Shaw Cimmerian 2.5 508 Orion
F3:	Porcelain Mosaic Tile: Series:  Grout Color:	Festival Dark Blend Matte 2" Hexagon  Mapei 103 Cobblestone
B1:	Cove Base: Profile: Size: Color:	Johnsonite w/ toe 4" Charcoal
B2:	NA	
W2:	Porcelain Tile: Series: Size:  Grout Color:	San Giorgio Gris 12' X 24"  Mapei 103 Cobblestone

**NOTES:**



1. FINISHED GRADE.
2. (1) #4 CONTINUOUS IN GROUTED BOND BEAM.
3. 8" MASONRY WALL WITH #5 VERTICALS AT 48" O.C. OFFSET IN WALL - GROUT SOLID BELOW GRADE.
4. DOWELS TO MATCH AND LAP VERTICAL WALL REINFORCING PER G.S.N. - ALTERNATE BENDS.
5. (4) #5 CONTINUOUS.
6. CONCRETE FOOTING.
7. FINISHED GRADE OR CONCRETE SLAB WHERE OCCURS.
8. 3'-0" MAXIMUM.
9. 3/4" DIA. WEEP HOLES AT 6'-0" O.C.
10. 1'-0" SQUARE GRAVEL ROCK POCKET WITH 40% VOIDS. BOTTOM OF POCKET SHALL BE 8" ABOVE LOWER FINISHED GRADE.
11. RAILING WHERE OCCURS PER ARCHITECTURAL DRAWINGS. MAX HEIGHT = 4'-0".

**TYPICAL NOTES:**

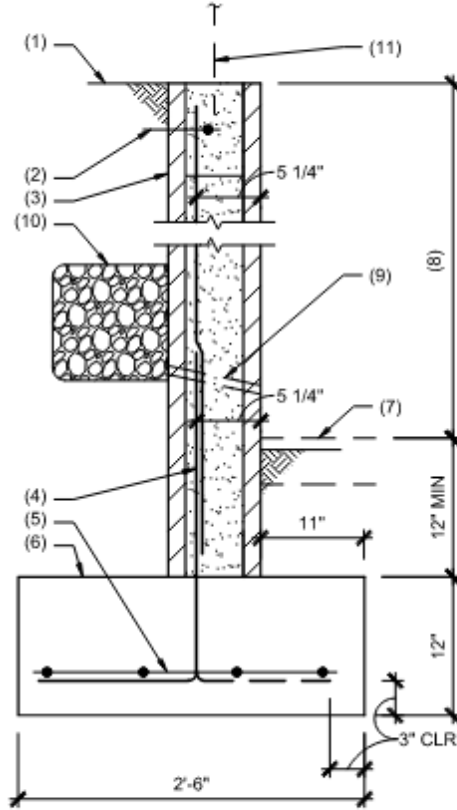
- STEP FOOTING PER TYPICAL DETAIL AS REQUIRED.
- PROVIDE MASONRY CONTROL JOINTS PER TYPICAL DETAIL AT 16'-0" O.C.
- SEE ARCH. AND/OR CIVIL DRAWINGS FOR LOCATION OF WALLS.



**SK1** 3'-0" MASONRY RETAINING WALL

		<p><b>DEL SOL CLUBHOUSE</b></p>								
		<table border="1" style="width: 100%; border-collapse: collapse;"> <tr> <td style="width: 10%;">project</td> <td>23038</td> </tr> <tr> <td>engineer</td> <td>WCH</td> </tr> <tr> <td>drafter</td> <td>WCH</td> </tr> <tr> <td>date</td> <td>09/29/23</td> </tr> </table>	project	23038	engineer	WCH	drafter	WCH	date	09/29/23
project	23038									
engineer	WCH									
drafter	WCH									
date	09/29/23									

revisions		
#	date	comment
##	MM/DD/YY	INFO

**NOTES:**

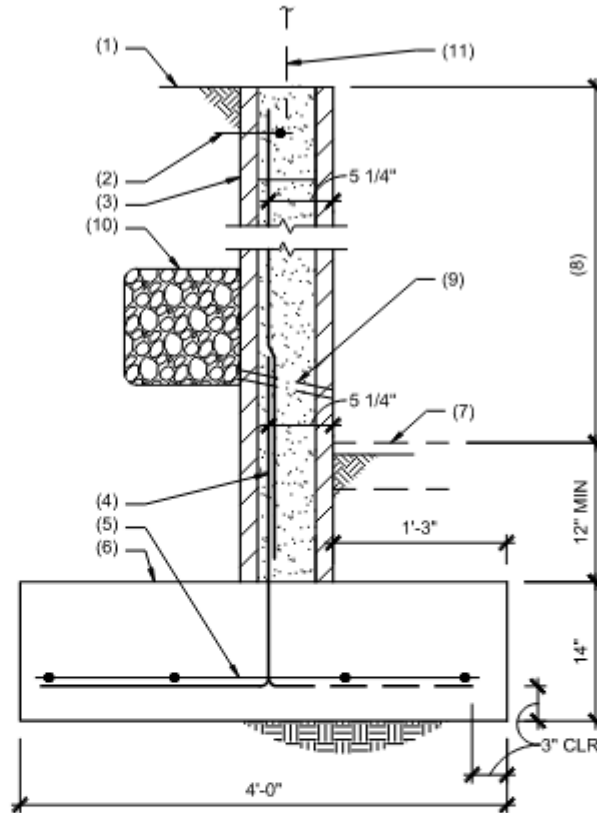

1. FINISHED GRADE.
2. (1) #4 CONTINUOUS IN GROUTED BOND BEAM.
3. 8" MASONRY WALL WITH #5 VERTICALS AT 16" O.C. OFFSET IN WALL - GROUT SOLID BELOW GRADE.
4. DOWELS TO MATCH AND LAP VERTICAL WALL REINFORCING PER G.S.N. - ALTERNATE BENDS.
5. (4) #5 CONTINUOUS.
6. CONCRETE FOOTING.
7. FINISHED GRADE OR CONCRETE SLAB WHERE OCCURS.
8. 5'-0" MAXIMUM.
9. 3/4" DIA. WEEP HOLES AT 6'-0" O.C.
10. 1'-0" SQUARE GRAVEL ROCK POCKET WITH 40% VOIDS. BOTTOM OF POCKET SHALL BE 8" ABOVE LOWER FINISHED GRADE.
11. RAILING WHERE OCCURS PER ARCHITECTURAL DRAWINGS. MAX HEIGHT = 4'-0".



**TYPICAL NOTES:**

- STEP FOOTING PER TYPICAL DETAIL AS REQUIRED.
- PROVIDE MASONRY CONTROL JOINTS PER TYPICAL DETAIL AT 20'-0" O.C.
- SEE ARCH. AND/OR CIVIL DRAWINGS FOR LOCATION OF WALLS.

**SK2** 5'-0" MASONRY RETAINING WALL

		<h2 style="margin: 0;">DEL SOL CLUBHOUSE</h2>															
		<table border="1" style="width: 100%; border-collapse: collapse;"> <tr> <td style="width: 10%; padding: 2px;">project</td> <td style="padding: 2px;">23038</td> </tr> <tr> <td style="padding: 2px;">engineer</td> <td style="padding: 2px;">WCH</td> </tr> <tr> <td style="padding: 2px;">drafter</td> <td style="padding: 2px;">WCH</td> </tr> <tr> <td style="padding: 2px;">date</td> <td style="padding: 2px;">09/29/23</td> </tr> </table>	project	23038	engineer	WCH	drafter	WCH	date	09/29/23	<h1 style="margin: 0;">SK2</h1>						
		project	23038														
engineer	WCH																
drafter	WCH																
date	09/29/23																
<table border="1" style="width: 100%; border-collapse: collapse;"> <thead> <tr> <th style="width: 5%; padding: 2px;">#</th> <th style="width: 15%; padding: 2px;">date</th> <th style="width: 80%; padding: 2px;">comment</th> </tr> </thead> <tbody> <tr> <td style="padding: 2px;">##</td> <td style="padding: 2px;">MM/DD/YY</td> <td style="padding: 2px;">INFO</td> </tr> <tr> <td style="padding: 2px;"> </td> <td style="padding: 2px;"> </td> <td style="padding: 2px;"> </td> </tr> <tr> <td style="padding: 2px;"> </td> <td style="padding: 2px;"> </td> <td style="padding: 2px;"> </td> </tr> </tbody> </table>	#	date	comment	##	MM/DD/YY	INFO							<table border="1" style="width: 100%; border-collapse: collapse;"> <tr> <td style="width: 10%; padding: 2px;">sheet</td> <td style="padding: 2px;"> </td> </tr> <tr> <td style="padding: 2px;">reference</td> <td style="padding: 2px;">RETAINING WALL</td> </tr> </table>	sheet		reference	RETAINING WALL
#	date	comment															
##	MM/DD/YY	INFO															
sheet																	
reference	RETAINING WALL																

**NOTES:**



1. FINISHED GRADE.
2. (1) #4 CONTINUOUS IN GROUTED BOND BEAM.
3. 8" MASONRY WALL WITH #5 VERTICALS AT 16" O.C. OFFSET IN WALL - GROUT SOLID BELOW GRADE.
4. DOWELS TO MATCH AND LAP VERTICAL WALL REINFORCING PER G.S.N. - ALTERNATE BENDS.
5. (4) #5 CONTINUOUS.
6. CONCRETE FOOTING.
7. FINISHED GRADE OR CONCRETE SLAB WHERE OCCURS.
8. 6'-0" MAXIMUM.
9. 3/4" DIA. WEEP HOLES AT 6'-0" O.C.
10. 1'-0" SQUARE GRAVEL ROCK POCKET WITH 40% VOIDS. BOTTOM OF POCKET SHALL BE 8" ABOVE LOWER FINISHED GRADE.
11. (1) #4 CONTINUOUS.
12. #4 VERTICAL AT 12" O.C.
13. RAILING WHERE OCCURS PER ARCHITECTURAL DRAWINGS. MAX HEIGHT = 4'-0".

**TYPICAL NOTES:**

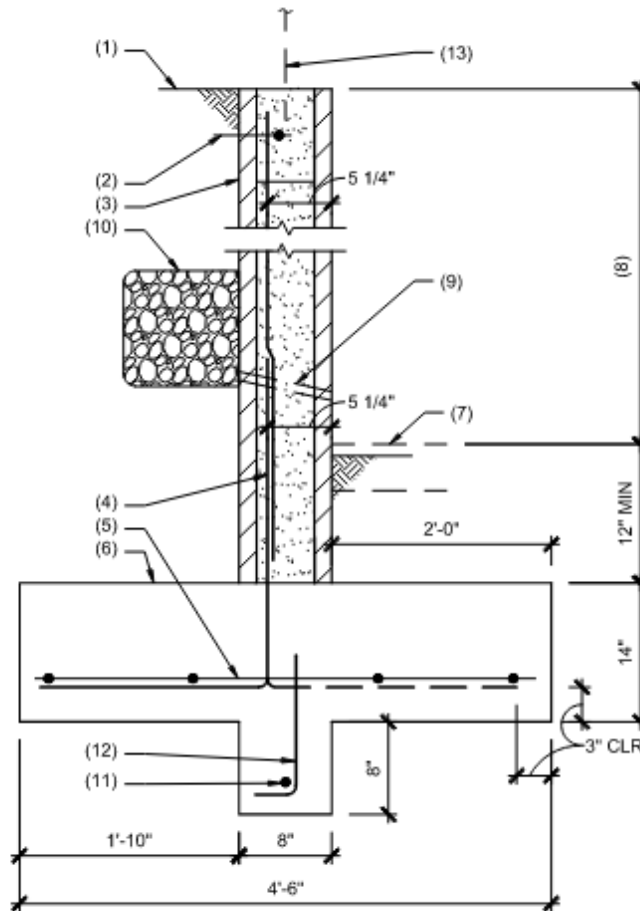
- STEP FOOTING PER TYPICAL DETAIL AS REQUIRED.
- PROVIDE MASONRY CONTROL JOINTS PER TYPICAL DETAIL AT 20'-0" O.C.
- SEE ARCH. AND/OR CIVIL DRAWINGS FOR LOCATION OF WALLS.



**SK3** 6'-0" MASONRY RETAINING WALL

		<p><b>DEL SOL CLUBHOUSE</b></p>																							
		<table border="1" style="width: 100%; border-collapse: collapse;"> <thead> <tr> <th style="text-align: left;">revisions</th> <th style="text-align: left;">#</th> <th style="text-align: left;">date</th> <th style="text-align: left;">comment</th> </tr> </thead> <tbody> <tr> <td></td> <td>##</td> <td>MM/DD/YY</td> <td>INFO</td> </tr> <tr> <td> </td> <td> </td> <td> </td> <td> </td> </tr> <tr> <td> </td> <td> </td> <td> </td> <td> </td> </tr> </tbody> </table>	revisions	#	date	comment		##	MM/DD/YY	INFO									<table border="1" style="width: 100%; border-collapse: collapse;"> <tr> <td style="width: 50%;">project</td> <td style="width: 50%;">23038</td> </tr> <tr> <td>engineer</td> <td>WCH</td> </tr> <tr> <td>drafter</td> <td>WCH</td> </tr> <tr> <td>date</td> <td>09/29/23</td> </tr> </table>	project	23038	engineer	WCH	drafter	WCH
revisions	#	date	comment																						
	##	MM/DD/YY	INFO																						
project	23038																								
engineer	WCH																								
drafter	WCH																								
date	09/29/23																								
		<p><b>SK3</b></p>	<p>sheet</p>																						
		<p>reference</p>	<p>RETAINING WALL</p>																						